

Kermit Chair Assembly Instructions

TO UNPACK CHAIR

Remove Curves

Remove Leg Braces

Remove Chair Frame and Canvas

Unroll with Arm Tops Pointing Down

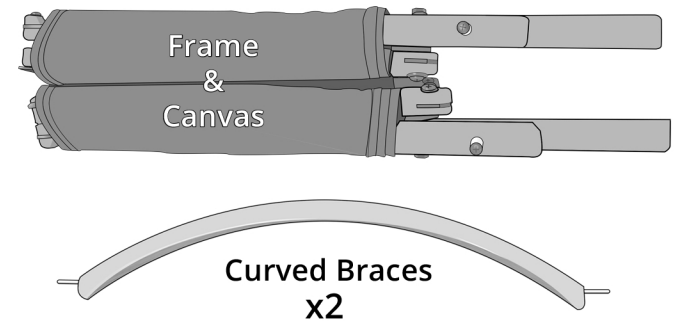
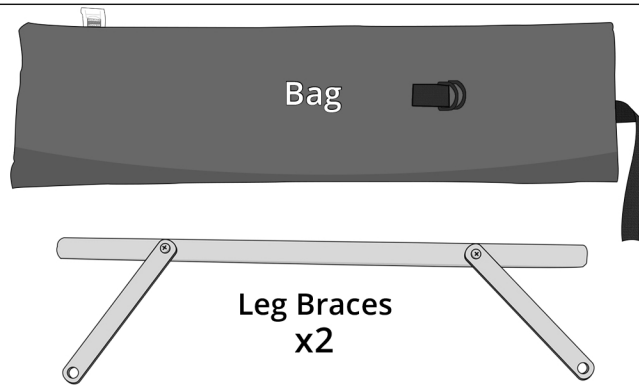

Chair Setup Steps

1. Install Leg Braces

- Insert ends of leg brace into holes in the legs
- Move end of metal brace over stud and insert stud into hole in metal brace

2. Attach Curved Braces

- Slide curve pin into hole in back / seat rail
- Slide opposite pin into front / top of back / seat rail while pushing on latch until pin is fully seated, then secure latch
- Check that brace is fully seated on both sides

3. Open / Unfold Chair

- Open chair until spacers are secured against rear legs

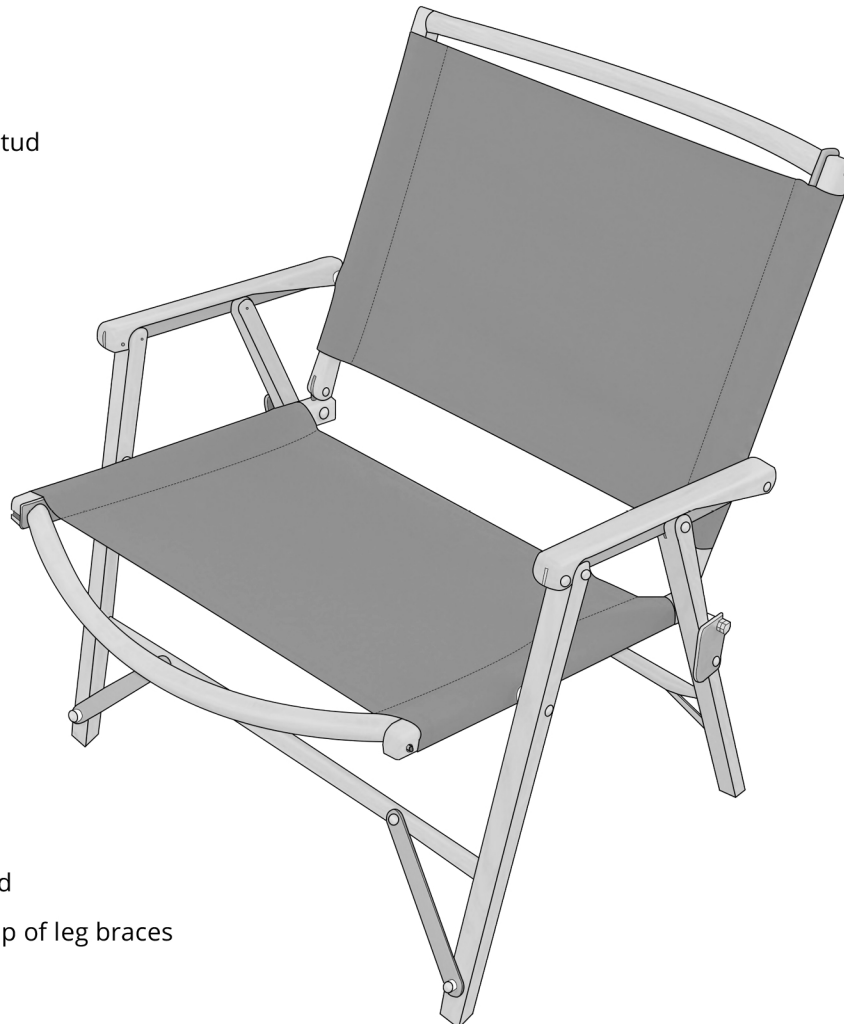

1.

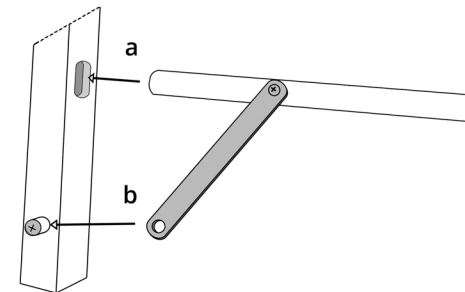

2.

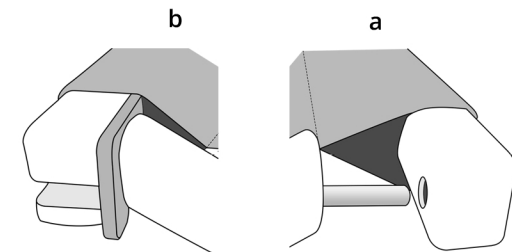

3.

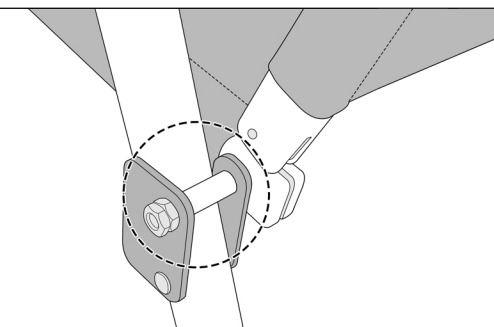

Packing The Chair

Reverse Setup Steps

- Place chair frame flat with top of arms facing down, then roll chair side frames toward each other
- Hold chair frame by the legs in one hand and insert top first into bag
- Insert leg braces centered on top of chair frames with aluminum latches facing downward
- Insert curved braces side by side into bag on top of leg braces

Kermit Chair Company

1330 FOSTER AVE.
SUITE 100
NASHVILLE, TN 37210
(888) 729-9836
WWW.KERMITCHAIR.COM
info@kermitchair.com

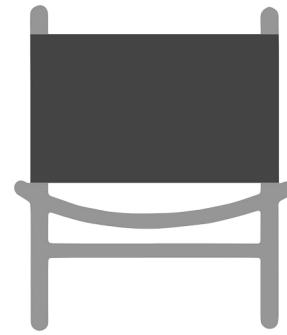

THE KERMIT CHAIR QUALITY GUARANTEE

30-DAY MONEY BACK GUARANTEE

Kermit Chair Company will return the purchase price less shipping to any purchaser not satisfied with the Kermit Chair on the condition that the chair is returned within 30 days from the date of purchase.

WARRANTY

The Kermit Chair has five-year limited warranty. This warranty covers defects in workmanship and materials which impact the function of the Kermit Chair. This warranty excludes damage caused by accident or abuse. For warranty service, please call or email.

GENERAL CUSTOMER SERVICE

Kermit Chair Company provides inspection and repair service for all of our products. Please call or email for details.

.....

Kermit Cupholder Instructions

Squeeze Cupholder between thumb and forefinger. Place hole over screw on leg.

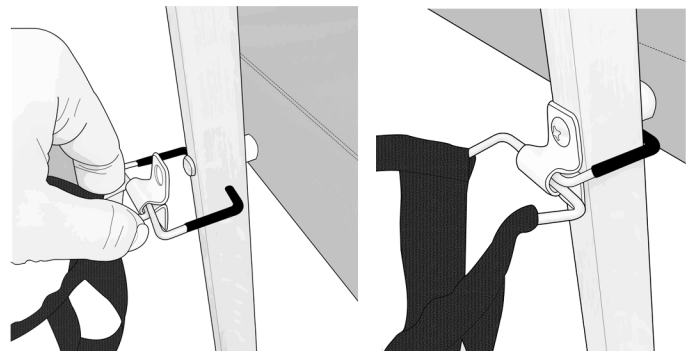

Kermit Leg Extension Instructions

Slide extension over leg, lifting end of metal brace to secure tabs. Short extensions on front legs, Long extensions on back legs.

